

Tous droits strictement reserves. Reproduction ou communication a des tiers int sous quelque forme que ce soit sans autorisation écrite du propriétaire.  
 Property of c BERG ELECTRONICS.  
 Droits de reproduction BERG ELECTRONICS by

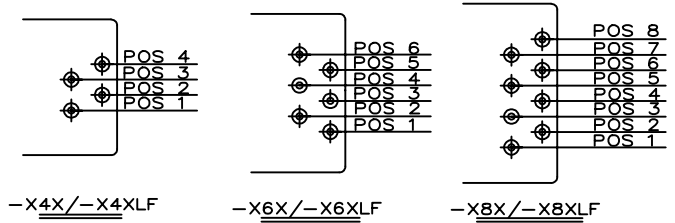

All rights strictly reserved. Reproduction or issue to third parties in any for whatever is not permitted without written authority from the proprietor.  
 Property of c BERG ELECTRONICS.  
 Copyright BERG ELECTRONICS by

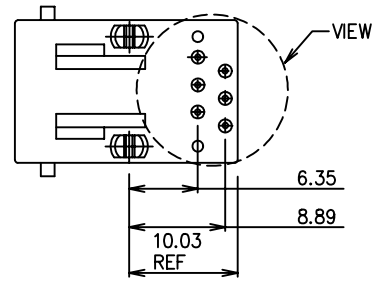
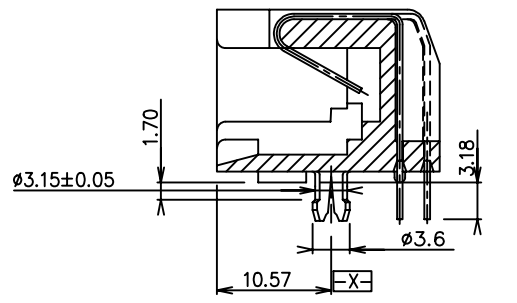
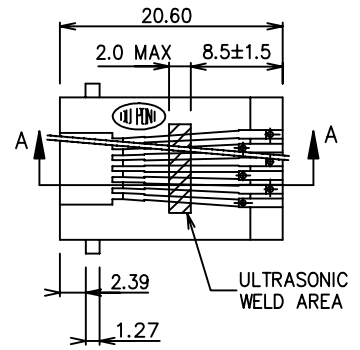
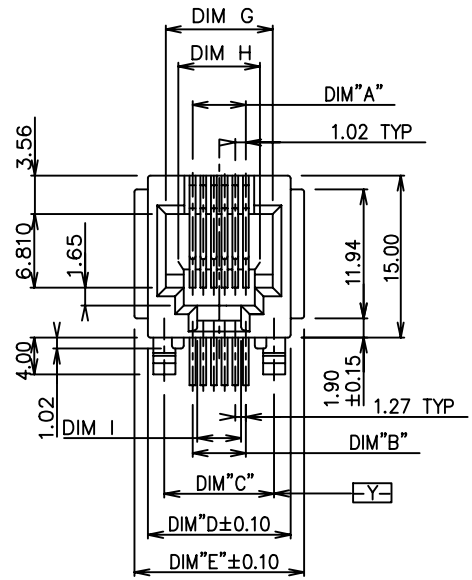

- NOTES:
1. RECOMMENDED P.C.B. THICKNESS 1.60 MM.
  2. HOUSING MATERIAL: ZYTEL FR50, COLOR: SEE TABLE.
  3. CONTACTS: PHOS BRONZE ALLOY UNS-C51000, 0.460 DIA. ROUND WIRE. PLATING SEE TABLE.
  4. PACKAGE PER BUS-14-164. (TUBE PACKAGING) WHEN PART NUMBER IS 88400-XXXT/-XXXTLF, APPLY PACKAGING SPEC. GES-14-351 (TRAY PACKAGING).
  5. THE PRODUCT MEETS EUROPEAN UNION DIRECTIVES AND OTHER COUNTRY REGULATIONS AS DESCRIBED IN GS-22-008.
  6. THE HOUSING WILL WITHSTAND EXPOSURE TO 260°C PEAK TEMPERATURE FOR 10 SECONDS IN A WAVE SOLDER APPLICATION WITH A 1.60mm MINIMUM THICK CIRCUIT BOARD.
  7. IF LF P/N PACKAGING MEETS GS-14-920 SPECIFICATION.

mat'l code				tolerance unless otherwise specified		CUSTOMER COPY		<a href="http://www.fciconnect.com">www.fciconnect.com</a>		
rev.	ecn no.	dr	date	linear	.0 ± 0.25	projection		title		
K	T90139	M W	04/06/99		.00 ± 0.13			SNAP-IN MODULAR JACK ASS'Y		
L	N05-0019	YS	01/27/05		.000 ± 0.05					
				angles	± 2'			product family		
				dr	KCHOU	04/26/92	unit	size		
				enr	TONY CHIEN	04/26/92	mm/inch	dwg no.		
				chr	TONY CHIEN	04/26/92	scale	sheet		
				appd	JENN TSAO	04/26/92	2/1	1 OF 2		
sheet index	revision	L	L							code
1	2									TWN
										sheet
										1 OF 2

Tous droits strictement réservés. Reproduction ou communication à des tiers interdite sans quelque forme que ce soit sans autorisation écrite du propriétaire.  
 Property of c BERG ELECTRONICS.  
 Droits de reproduction BERG ELECTRONICS by



All rights strictly reserved. Reproduction or issue to third parties in any form without written authority from the proprietor.  
 Property of c BERG ELECTRONICS.  
 Copyright BERG ELECTRONICS by

DIM.	NO OF POS	DIM A	DIM B	DIM C	DIM D	DIM E	DIM G	DIM H	DIM I	LOADED POS	REMARK
88400-X44/-X44LF	4	3.05	3.81	7.62	11.20	13.72	7.87	5.50	3.05	ALL POS	
88400-X42/-X42LF										2,3	
88400-X66/-X66LF	6	5.08	6.35	10.16	13.20	15.72	9.906	6.60	4.06	ALL POS	
88400-X64/-X64LF										2,3,4,5	
88400-X62/-X62LF										3,4	
88400-X88/-X88LF	8	7.11	8.89	11.43	15.24	17.76				ALL POS	NOT AVAILABLE
88400-X86/-X86LF										2,3,4,5,6,7	
88400-X84/-X84LF										3,4,5,6	

PLATING & HSG COLOR CODE	PLATING	HSG COLOR
0	30 u" G.X.T.	BLACK
1	15 u" GOLD.	
2	20 u" GFPD.	
3	30 u" GOLD.	
4	15 u" G.X.T.	
5	50 u" GOLD.	
6	6 u" GOLD.	
7	2 u" GOLD.	

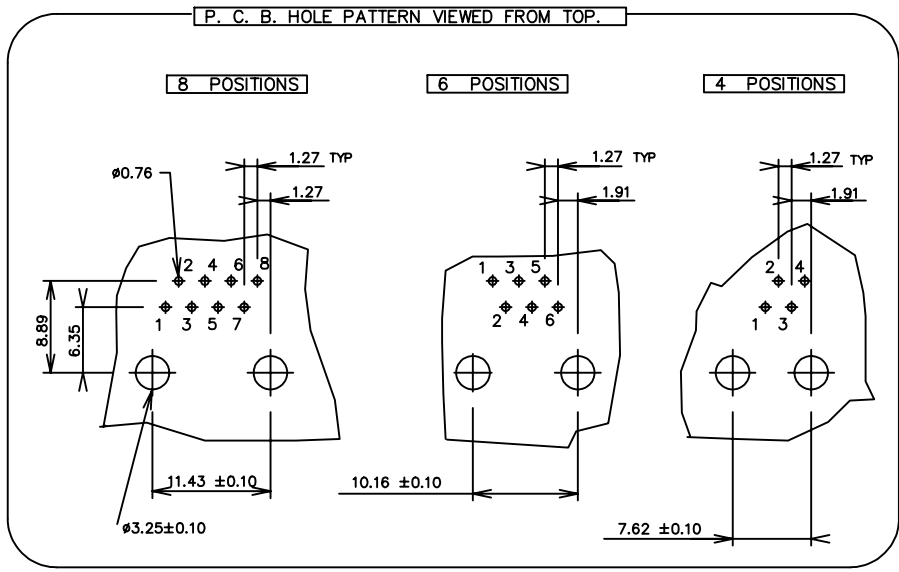

mat'l code				tolerance unless otherwise specified		CUSTOMER COPY		FCJ www.fcjconnect.com	
rev.	ecn no.	dr	date	linear	.0 $\pm$ 0.25	projection	title		
L				angles	.00 $\pm$ 0.13 .000 $\pm$ 0.05 $\pm 2'$		SNAP-IN MODULAR JACK ASS'Y		
				dr	KCHOU 04/26/92	unit	product family		code
				enr	TONY CHIEN 04/26/92	mm/inch	size		TWN
				chr	TONY CHIEN 04/26/92	scale	88400		sheet
				appd	JENN TSAO 04/26/92	2/1	2 OF 2		
sheet	revision								
index	sheet								